



solidThinking Embed - formerly known as VisSim Embedded - is an intuitive graphical environment for model-based embedded development. Diagrams are automatically converted to highly-optimized and compact code, which is essential for low-cost microprocessors and high-speed sampling rates. The code can be verified, debugged and tuned with off-line simulation before downloading it to the target microcontroller (MCU).

Product Highlights

- Extensive Block Library for Embedded Systems
- Highly efficient diagram-to-code capability
 - Visual real-time operating system
 - Fast run time
 - Low memory footprint
 - Human readable code
- State charts
 - Graphical editing of Finite State Machines
 - Simulation and code generation
- Interactive SIL, PIL, and HIL
 - Parameter tuning while system is in operation
 - Gaining system insight through data logging, buffering, and digital scopes
- Scaled, Fixed-Point Algorithms

Benefits

Rapid Development of Control Systems

solidThinking Embed provides a complete tool chain for the development of embedded control systems covering Software-in-the-Loop, Processor-in-the-Loop as well as Hardware-in-the-Loop simulations.

You can make changes to a control diagram, and compile and download it to the target MCU in seconds. Then, while the system is operating, you can interactively update the control parameters.

Using powerful data logging, buffering, and digital scoping blocks, you can gain insight into the control algorithms deployed on the target MCU in real time.

No Hand-Coding Required

Turning control diagrams into executable, real-time capable code used to require an experienced embedded software developer. With solidThinking Embed's code generator a control design engineer can easily try out new algorithms on a target hardware without the need of hand-coding.

Affordable and Easily Configured Solution

solidThinking Embed comes in the basic configuration already with most of the tools needed for embedded development including state charts, target support, fixed-point algorithms, efficient code generator, motor control libraries, and a lot more. This results in an affordable and easy configurable development environment.

Learn more:
solidThinking.com/Embed

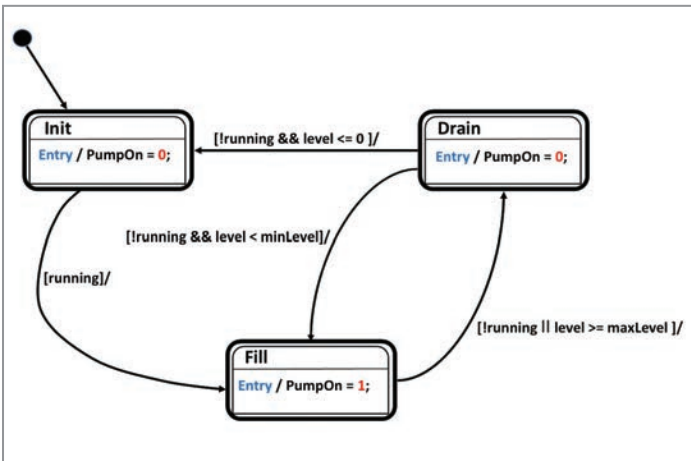

Draining Tank Logic with StateCharts

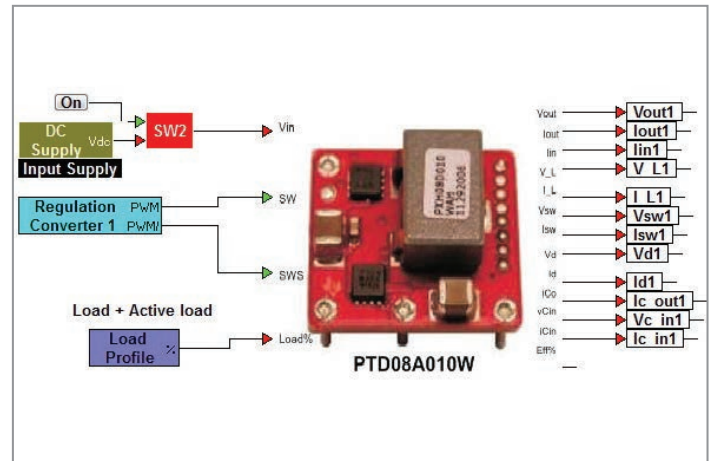

Digital Power Application

Capabilities

Extensive Block Libraries for Embedded Systems

Using solidThinking Embed, you can build a model of your entire system, including the control algorithm and the plant.

The control system can be built in scaled, fixed-point arithmetic, while the plant is built in full-precision, floating point arithmetic. For model construction, Embed provides extensive block libraries, including:

- TI C2000 Motor Control block library
- TI InstaSPIN block library
- On-chip peripheral block library
- Fixed-point block library
- Motor block library

State Charts

solidThinking Embed supports OMG UML 2.1 compliant graphical state chart editing, simulation and code generation. Combined with a built-in C interpreter, this allows fast and reliable development of complex control applications. Whether you need to decode a serial protocol or step through a complex start up or shut down sequence, the State Chart block library accelerates these tasks.

Diagram-to-Code

solidThinking Embed generates efficient and compact ANSI C code for discrete, continuous, and hybrid systems. MCU target support includes a report to display the COFF section sizes of the generated execution file.

For example, code generated for closed-loop motor control - including PI controller, digital output, PWM, and encoder peripherals - runs at 300KHz on a 150MHz F28335 MCU.

The memory footprint is:

Code size: 2095 bytes
 Initialized data: 501 bytes
 Uninitialized data: 504 bytes

Interactive Hardware-in-the-Loop Simulations

In MCU-in-the-loop simulation, the plant model runs on the host computer in solidThinking Embed while the control algorithm runs in real time on the target MCU. Real-time communication between the target MCU and Embed is performed via a JTAG hotlink. Embed's GUI is retained while you tune parameters and monitor real-time data.

Embed also supports a PIL-synchronous communication mode that runs the target in lock step with the simulation, allowing easy verification of embedded algorithms.

Scaled, Fixed-Point Algorithms

The Fixed-Point block library lets you perform simulation and efficient code generation of scaled, fixed-point operations.

Overflow and precision loss effects are easily seen and corrected at simulation time. Auto-scaling speeds fixed-point development, while in-line code generation creates fast target code.

Target Hardware Support

The target-specific blocks let you easily program on-chip devices. These blocks include analog ADC, ePWM, eCAP (event capture), SPI, SCI (RS232 serial), I2C, digital GPIO, QEP (quadrature encoder), and CAN 2.0.

Add-ons

solidThinking Embed/Digital Power Designer

Provides a library of components and sub-system models (including power converters, controllers, compensators, sources, and more) for digital power applications.

solidThinking Embed/Comm

Lets you model end-to-end communication systems at the signal or physical level. It provides fast and accurate solutions for analog, digital, and mixed-mode communication systems.